

CAIXA PARA BATERIAS BATTERY BOX

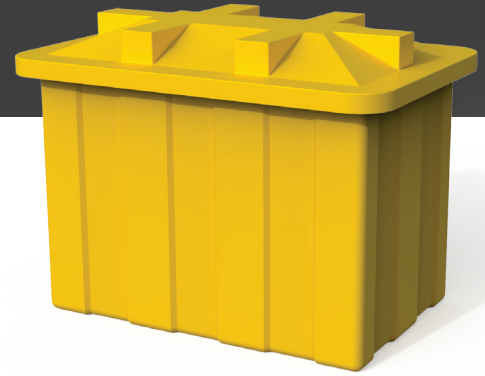

PT

Características

- ☑ Insensibilidade à corrosão
- ☑ Estanquidade total

Material

- ☑ Polietileno

EN

Characteristics

- ☑ Insensitivity to corrosion
- ☑ Total tightness

Material

- ☑ Polyethylene

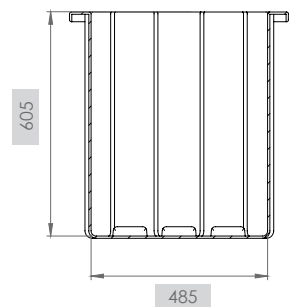
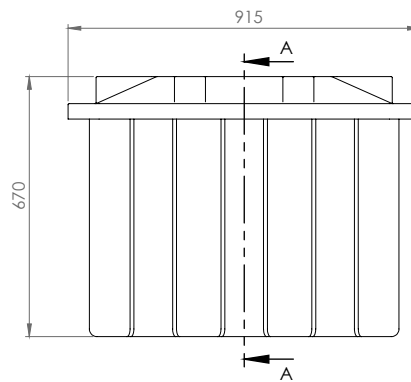
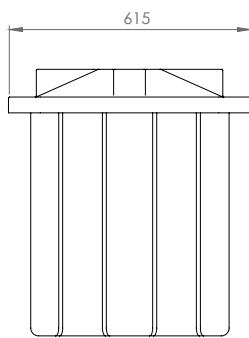

SECTION A-A

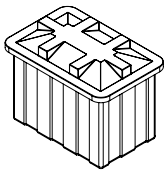

REF.	LARGURA WIDTH	LARGURA A-A A-A WIDTH	ALTURA HEIGHT	ALTURA A-A A-A HEIGHT	COMPRIMENTO LENGTH	COR COLOR	CAPACIDADE VOLUME
AMBI5703	615 mm	485 mm	670 mm	605 mm	915 mm	RAL 1021 (Amarelo)	10 kg

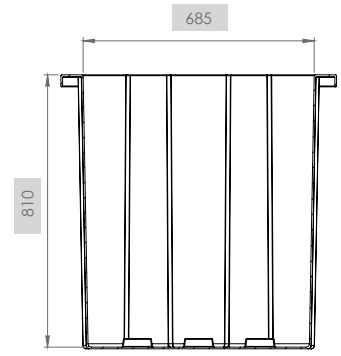
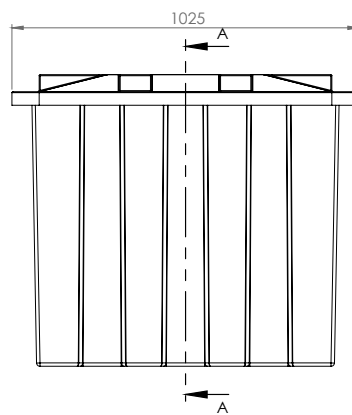
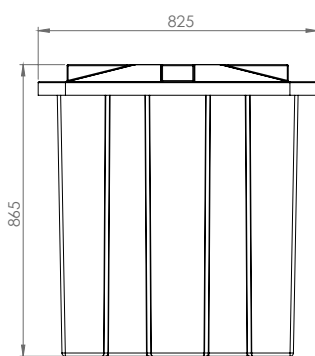

SECTION A-A

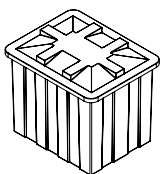

REF.	LARGURA WIDTH	LARGURA A-A A-A WIDTH	ALTURA HEIGHT	ALTURA A-A A-A HEIGHT	COMPRIMENTO LENGTH	COR COLOR	CAPACIDADE VOLUME
AMBI5704	825 mm	685 mm	865 mm	810 mm	1025 mm	RAL 1021 (Amarelo)	20 kg